

15-213

“The course that gives CMU its Zip!”

Internetworking November 10, 2006

Topics

- Client-server programming model
- Networks
- Internetworks
- Global IP Internet
 - IP addresses
 - Domain names
 - Connections

class21.ppt

A Client-Server Transaction

Most network applications are based on the client-server model:

- A **server** process and one or more **client** processes
- Server manages some **resource**.
- Server provides **service** by manipulating resource for clients
- Server activated by request from client (vending machine analogy)

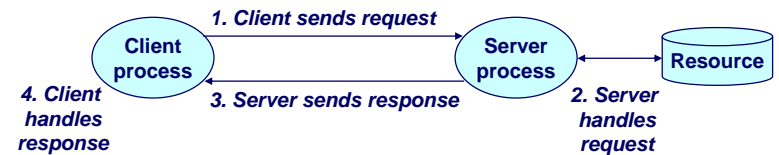

Note: clients and servers are processes running on hosts (can be the same or different hosts).

- 2 -

15-213, F'06

Hardware Org of a Network Host

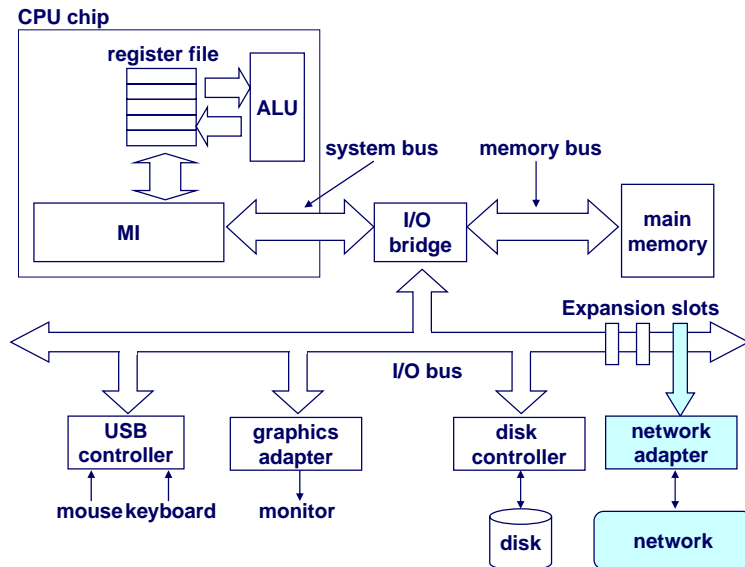

- 3 -

15-213, F'06

Computer Networks

A network is a hierarchical system of boxes and wires organized by geographical proximity

- SAN (System Area Network) spans cluster or machine room
Switched Ethernet, Quadrics QSW, ...
- LAN (local area network) spans a building or campus.
Ethernet is most prominent example.
- WAN (wide-area network) spans country or world.
Typically high-speed point-to-point phone lines.

An **internetwork** (**internet**) is an interconnected set of networks.

- The Gobar IP Internet (uppercase “I”) is the most famous example of an internet (lowercase “i”)

Let’s see how we would build an internet from the ground up.

- 4 -

15-213, F'06

Lowest Level: Ethernet Segment

Ethernet segment consists of a collection of *hosts* connected by wires (twisted pairs) to a *hub*.

Spans room or floor in a building.

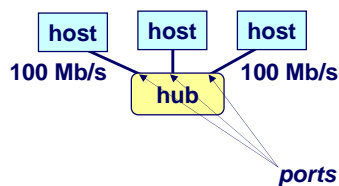

Operation

- Each Ethernet adapter has a unique 48-bit address.
- Hosts send bits to any other host in chunks called *frames*.
- Hub slavishly copies each bit from each port to every other port. Every host sees every bit.

Note: Hubs are on their way out. Bridges (switches, routers) became cheap enough to replace them (means no more broadcasting)

- 5 -

15-213, F'06

Next Level: Bridged Ethernet Segment

Spans building or campus.

Bridges cleverly learn which hosts are reachable from which ports and then selectively copy frames from port to port.

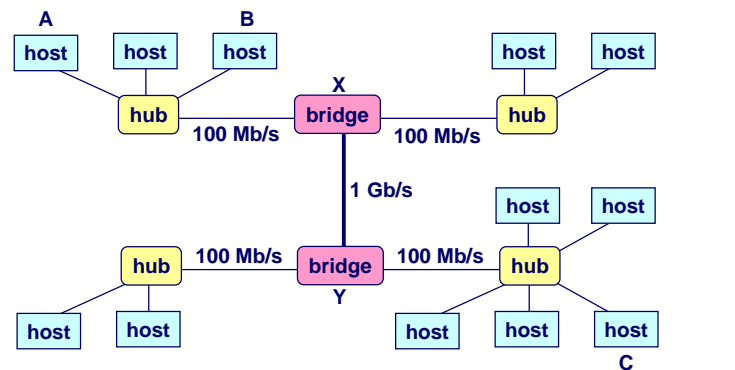

- 6 -

15-213, F'06

Conceptual View of LANs

For simplicity, hubs, bridges, and wires are often shown as a collection of hosts attached to a single wire:



- 7 -

15-213, F'06

Next Level: internets

Multiple incompatible LANs can be physically connected by specialized computers called *routers*.

The connected networks are called an *internet*.

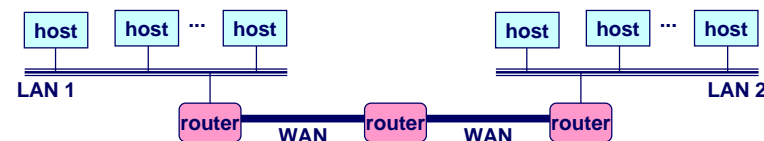

LAN 1 and LAN 2 might be completely different, totally incompatible LANs (e.g., Ethernet and Wifi, 802.11*, T1-links, DSL, ...)

- 8 -

15-213, F'06

Logical Structure of Internet

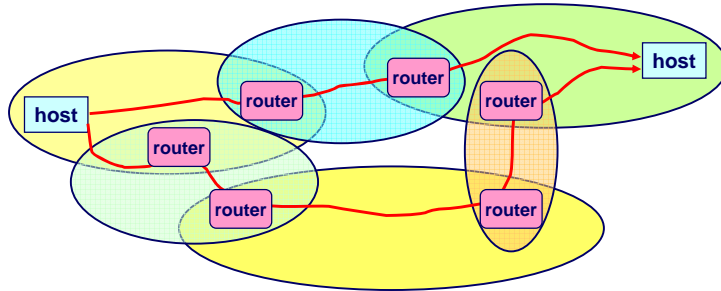

- Ad hoc interconnection of networks
 - No particular topology
 - Vastly different router & link capacities
- Send packets from source to destination by hopping through networks
 - Router forms bridge from one network to another
 - Different packets may take different routes

The Notion of an internet Protocol

How is it possible to send bits across incompatible LANs and WANs?

Solution: protocol software running on each host and router smooths out the differences between the different networks.

Implements an internet protocol (i.e., set of rules) that governs how hosts and routers should cooperate when they transfer data from network to network.

- TCP/IP is the protocol for the global IP Internet.

What Does an internet Protocol Do?

1. Provides a naming scheme

- An internet protocol defines a uniform format for **host addresses**.
- Each host (and router) is assigned at least one of these internet addresses that uniquely identifies it.

2. Provides a delivery mechanism

- An internet protocol defines a standard transfer unit (**packet**)
- Packet consists of **header** and **payload**
 - Header: contains info such as packet size, source and destination addresses.
 - Payload: contains data bits sent from source host.

Transferring Data Over an internet

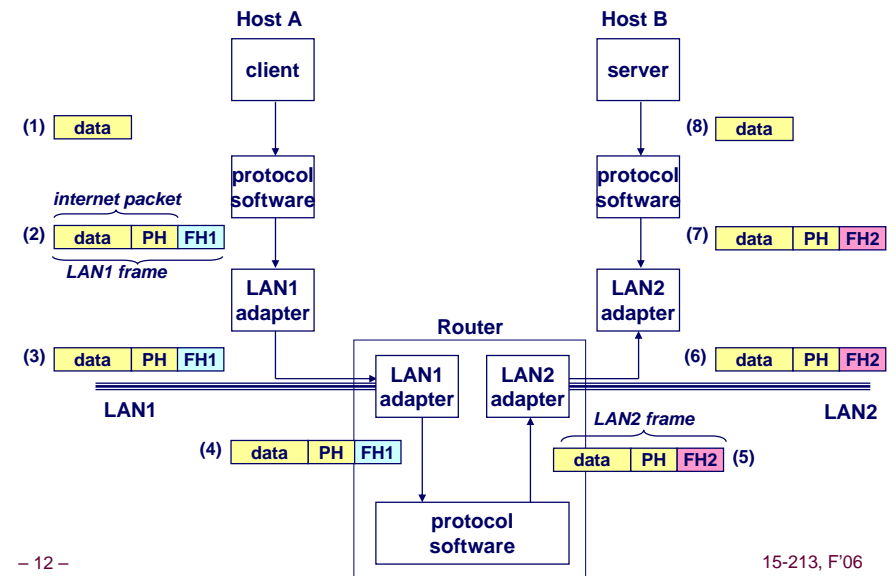

Other Issues

We are glossing over a number of important questions:

- What if different networks have different maximum frame sizes? (segmentation)
- How do routers know where to forward frames?
- How are routers informed when the network topology changes?
- What if packets get lost?

These (and other) questions are addressed by the area of systems known as *computer networking*.

Global IP Internet

Most famous example of an internet.

Based on the TCP/IP protocol family

- IP (Internet protocol) :
 - Provides basic naming scheme and unreliable delivery capability of packets (datagrams) from host-to-host.
- UDP (Unreliable Datagram Protocol)
 - Uses IP to provide unreliable datagram delivery from process-to-process.
- TCP (Transmission Control Protocol)
 - Uses IP to provide reliable byte streams from process-to-process over connections.

Accessed via a mix of Unix file I/O and functions from the *sockets interface*.

Hardware and Software Org of an Internet Application

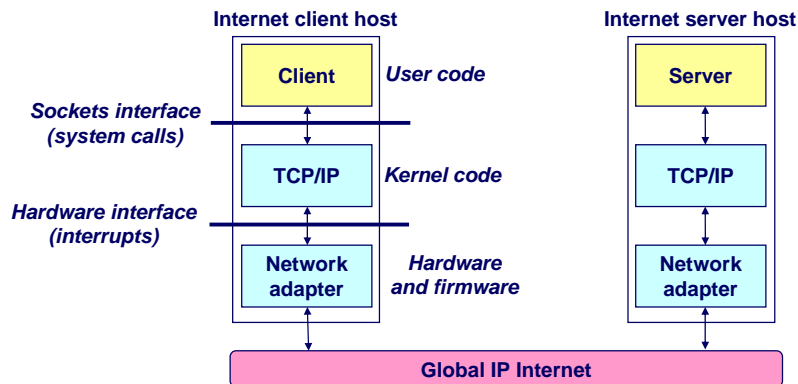

Basic Internet Components

An *Internet backbone* is a collection of routers (nationwide or worldwide) connected by high-speed point-to-point networks.

A *Network Access Point (NAP)* is a router that connects multiple backbones (sometimes referred to as *peers*).

Regional networks are smaller backbones that cover smaller geographical areas (e.g., cities or states)

A *point of presence (POP)* is a machine that is connected to the Internet.

Internet Service Providers (ISPs) provide dial-up or direct access to POPs.

NAP-Based Internet Architecture

NAPs link together commercial backbones provided by companies such as AT&T and Worldcom

Currently in the US there are about 50 commercial backbones connected by ~12 NAPs (peering points).

Similar architecture worldwide connects national networks to the Internet.

Internet Connection Hierarchy

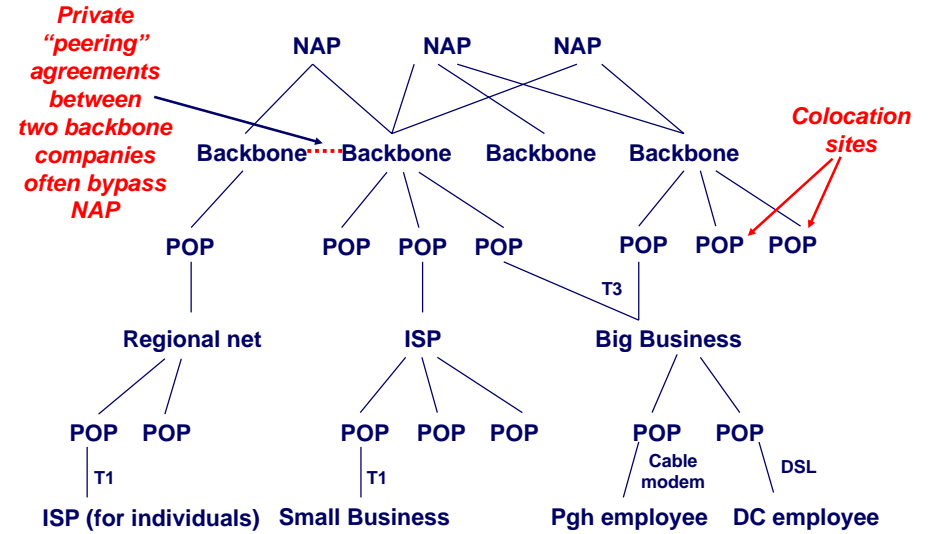

Network Access Points (NAPs)

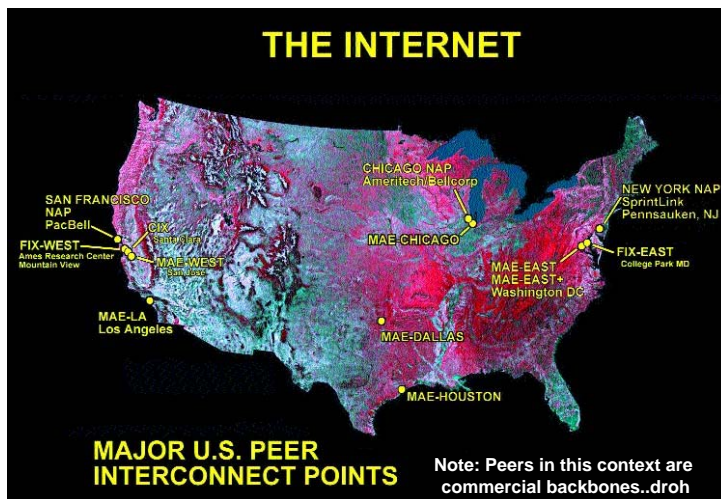

Source: Boardwatch.com

MCI/WorldCom/UUNET Global Backbone

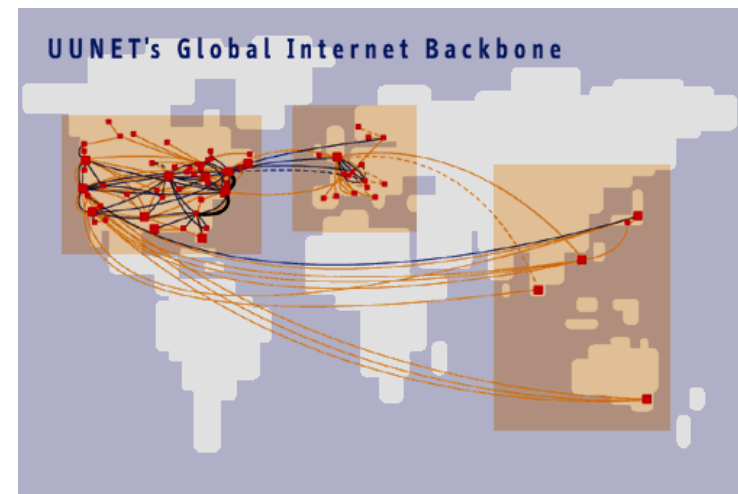

Source: Boardwatch.com

Naming and Communicating on the Internet

Original Idea

- Every node on Internet would have unique IP address
 - Everyone would be able to talk directly to everyone
- No secrecy or authentication
 - Messages visible to routers and hosts on same LAN
 - Possible to forge source field in packet header

Shortcomings

- There aren't enough IP addresses available
- Don't want everyone to have access or knowledge of all other hosts
- Security issues mandate secrecy & authentication

- 21 -

15-213, F'06

Evolution of Internet: Naming

Dynamic Address Assignment

- Most hosts don't need to have known address
 - Only those functioning as servers
- DHCP protocol
 - Local ISP assigns address for temporary use

Example:

- My laptop at CMU
 - IP address 128.2.220.249 (bryant-tp3.cs.cmu.edu)
 - Assigned statically
- My laptop at home
 - IP address 205.201.7.7 (dhcp-7-7.dsl.telera.com)
 - Assigned dynamically by my ISP for my DSL service

- 22 -

15-213, F'06

Evolution of Internet: Firewalls

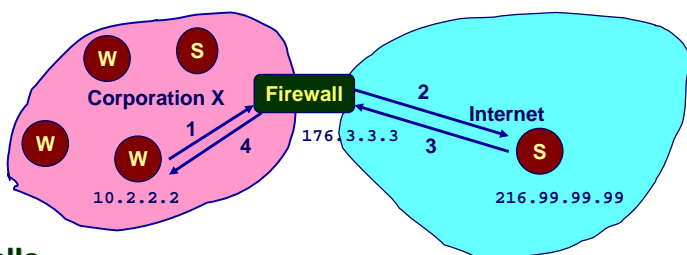

Firewalls

- Hides organizations nodes from rest of Internet
 - Use local IP addresses within organization
 - For external service, provides proxy service
1. Client request: src=10.2.2.2, dest=216.99.99.99
 2. Firewall forwards: src=176.3.3.3, dest=216.99.99.99
 3. Server responds: src=216.99.99.99, dest=176.3.3.3
 4. Firewall forwards response: src=216.99.99.99, dest=10.2.2.2

- 23 -

15-213, F'06

Virtual Private Networks

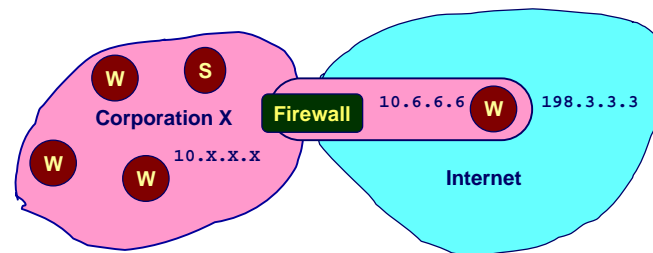

Supporting Road Warrior

- Employee working remotely with assigned IP address 198.3.3.3
- Wants to appear to rest of corporation as if working internally
 - From address 10.6.6.6
 - Gives access to internal services (e.g., ability to send mail)

Virtual Private Network (VPN)

- Overlays private network on top of regular Internet

- 24 -

15-213, F'06

A Programmer's View of the Internet

1. Hosts are mapped to a set of 32-bit *IP addresses*.

- 128.2.203.179

2. The set of IP addresses is mapped to a set of identifiers called Internet *domain names*.

- 128.2.203.179 is mapped to www.cs.cmu.edu

3. A process on one Internet host can communicate with a process on another Internet host over a *connection*.

1. IP Addresses

32-bit IP addresses are stored in an *IP address struct*

- IP addresses are always stored in memory in network byte order (big-endian byte order)
- True in general for any integer transferred in a packet header from one machine to another.
 - E.g., the port number used to identify an Internet connection.

```
/* Internet address structure */
struct in_addr {
    unsigned int s_addr; /* network byte order (big-endian) */
};
```

Handy network byte-order conversion functions:

- htonl: convert long int from host to network byte order.
- htons: convert short int from host to network byte order.
- ntohl: convert long int from network to host byte order.
- ntohs: convert short int from network to host byte order.

Dotted Decimal Notation

By convention, each byte in a 32-bit IP address is represented by its decimal value and separated by a period

- IP address 0x8002C2F2 = 128.2.194.242

Functions for converting between binary IP addresses and dotted decimal strings:

- `inet_aton`: converts a dotted decimal string to an IP address in network byte order.
- `inet_ntoa`: converts an IP address in network byte order to its corresponding dotted decimal string.
- “n” denotes network representation. “a” denotes application representation.

IP Address Structure

IP (V4) Address space divided into classes:

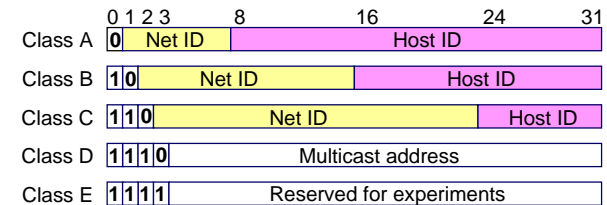

Network ID Written in form w.x.y.z/n

- n = number of bits in host address
- E.g., CMU written as 128.2.0.0/16
 - Class B address

Unrouted (private) IP addresses:

10.0.0.0/8 172.16.0.0/12 192.168.0.0/16

2. Internet Domain Names

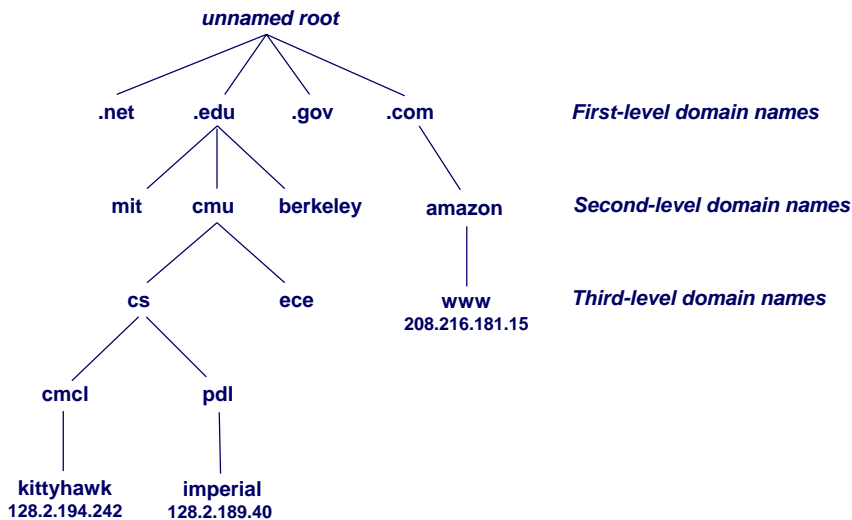

- 29 -

15-213, F'06

Domain Naming System (DNS)

The Internet maintains a mapping between IP addresses and domain names in a huge worldwide distributed database called *DNS*.

- Conceptually, programmers can view the DNS database as a collection of millions of *host entry structures*:

```
/* DNS host entry structure */
struct hostent {
    char *h_name; /* official domain name of host */
    char **h_aliases; /* null-terminated array of domain names */
    int h_addrtype; /* host address type (AF_INET) */
    int h_length; /* length of an address, in bytes */
    char **h_addr_list; /* null-terminated array of in_addr structs */
};
```

Functions for retrieving host entries from DNS:

- `gethostbyname`: query key is a DNS domain name.
- `gethostbyaddr`: query key is an IP address.

- 30 -

15-213, F'06

Properties of DNS Host Entries

Each host entry is an equivalence class of domain names and IP addresses.

Each host has a locally defined domain name `localhost` which always maps to the *loopback address* `127.0.0.1`

Different kinds of mappings are possible:

- Simple case: 1-1 mapping between domain name and IP addr:
 - `kittyhawk.cmcl.cs.cmu.edu` maps to `128.2.194.242`
- Multiple domain names mapped to the same IP address:
 - `eecs.mit.edu` and `cs.mit.edu` both map to `18.62.1.6`
- Multiple domain names mapped to multiple IP addresses:
 - `aol.com` and `www.aol.com` map to multiple IP addrs.
- Some valid domain names don't map to any IP address:
 - for example: `cmcl.cs.cmu.edu`

- 31 -

15-213, F'06

A Program That Queries DNS

```
int main(int argc, char **argv) { /* argv[1] is a domain name */
    char **pp; /* or dotted decimal IP addr */
    struct in_addr addr;
    struct hostent *hostp;

    if (inet_aton(argv[1], &addr) != 0)
        hostp = Gethostbyaddr((const char *)&addr, sizeof(addr),
                              AF_INET);

    else
        hostp = Gethostbyname(argv[1]);
    printf("official hostname: %s\n", hostp->h_name);

    for (pp = hostp->h_aliases; *pp != NULL; pp++)
        printf("alias: %s\n", *pp);

    for (pp = hostp->h_addr_list; *pp != NULL; pp++) {
        addr.s_addr = ((struct in_addr *)*pp)->s_addr;
        printf("address: %s\n", inet_ntoa(addr));
    }
}
```

- 32 -

15-213, F'06

Querying DNS from the Command Line

Domain Information Groper (`dig`) provides a scriptable command line interface to DNS.

```
linux> dig +short kittyhawk.cmcl.cs.cmu.edu
128.2.194.242
linux> dig +short -x 128.2.194.242
KITTYHAWK.CMCL.CS.CMU.EDU.
linux> dig +short aol.com
205.188.145.215
205.188.160.121
64.12.149.24
64.12.187.25
linux> dig +short -x 64.12.187.25
aol-v5.websys.aol.com.
```

3. Internet Connections

Clients and servers communicate by sending streams of bytes over **connections**:

- Point-to-point, full-duplex (2-way communication), and reliable.

A **socket** is an endpoint of a connection

- Socket address is an `IPAddress:port` pair

A **port** is a 16-bit integer that identifies a process:

- **Ephemeral port**: Assigned automatically on client when client makes a connection request
- **Well-known port**: Associated with some service provided by a server (e.g., port 80 is associated with Web servers)

A connection is uniquely identified by the socket addresses of its endpoints (**socket pair**)

- (`cliaddr:cliport`, `servaddr:servport`)

Putting it all Together: Anatomy of an Internet Connection

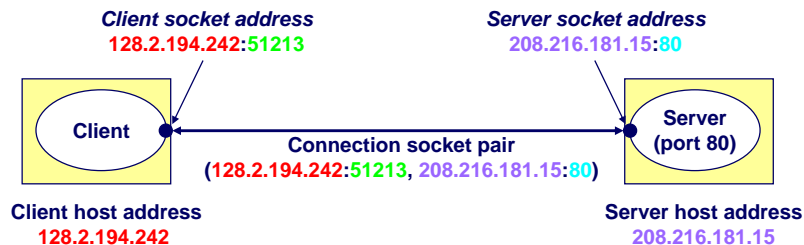

Next Time

How to use the sockets interface to establish Internet connections between clients and servers

How to use Unix I/O to copy data from one host to another over an Internet connection.